

SMART3G-C2-LD

with catalytic sensor

The SMART3G-C2-LD gas detector is designed to meet industrial requirements; the enclosure is explosion proof and can be installed in ATEX Zone 1 and, when equipped with dust adapter, in Zone 21.

The sensing element is housed in the stainless steel head. The pellistor sensors employed for the flammable gas detection show an excellent output linearity up to 100% LEL and fast time of response.

The gas detector has a 12-24 Vdc power supply and a standard 4-20 mA 3-wires output and three relays. Optionally, the SMART3G-C2-LD can be equipped with serial RS485 communication.

The aluminium enclosure has dimensions 145 x 187 x 108 mm. The enclosure has 3 cable entries 3/4" NPT threaded. The multi-color LED light ring assures an immediate visual indication of the detector status.

The gas detector can be ATEX marked as follows:

CE 0722 Ex II 2G Ex db IIC T5 Gb
Or, when equipped with dust adapter:

CE 0722 Ex II 2GD Ex db IIC T5 Gb
Ex tb IIIC T5 T100°C Db
IP65

The gas detector is IECEx complaint and can be marked as follows:

II 2G Ex db IIC T5 Gb
Or, when equipped with dust adapter:
II 2GD Ex db IIC T5 Gb
Ex tb IIIC T5 T100°C Db
IP65

SMART3G-C2-LD is SIL2 hardware and SIL3 software; with a redundant system also the hardware is SIL3.



Sensor

Application	Industrial area, ATEX Zone 1 and Zone 21 (when equipped with dust adapter, optional)
Sensing element	Catalytic
Predicted sensor lifetime	4 / 5 years
Gas detected	Flammable gas
Fullscale	0 - 100% LFL

Electrical data

Power supply	12-24 Vdc
Output	Analogue 4-20 mA output; 3 relay board; serial RS485 output (optional)
Maximum dissipated power	5.4 W
Relays contact ratings	1.0 A at 30 Vdc
Optical indications	Multi-color LED light ring
Acoustic indications	-

Environmental conditions

Storage temperature	-40 / +85°C
Operating temperature	-40 / +60°C *
Operating humidity	20 / 90% RH @40°C *
Operating pressure	80 / 120 kPa *
Air velocity	6 m/s *
Time of response	$t_{90} < 60 \text{ s}$; $t_{50} < 20 \text{ s}$ *

* Data tested with tests described in EN 60079-29-1 standard

External case

Material	Enclosure: aluminium pressure die-casting with epoxy paint chromating and chemically resistant Sensor head: stainless steel
Protection mode	Ex d : Explosion proof enclosure Ex t : Equipment dust ignition protection by enclosure (when equipped with dust adapter, optional)
Dimensions	145 x 187 x 128 mm
Weight	1900 g
Cable entries	3 x 3/4" NPT
IP grade	IP65

Compliance

EMC	EN 61000-6-3:2007 + A1:2011; EN 50270:2015
ATEX	ATEX directive 2014/34/UE EN IEC 60079-0:2018 EN 60079-1:2014 EN 60079-31:2014 EN 60079-29-1:2016
IECEX	IEC 60079-0:2011 IEC 60079-1:2014 IEC 60079-31:2013
SIL	EN 61508:2010 Parts 1, 2, 3, 4, 5, 6, 7 EN 50402:2017

SMART3G-C2-LD

with catalytic sensor

Product codes

ATEX code

S2155ME-LD	Methane gas detector	ST / LW / E3 / S3	S2155IB-LD	Isobutane gas detector	ST / LW / E3 / S3
S2155GP-LD	LPG gas detector	ST / LW / E3 / S3	S2155IT-LD	Iso butyl alcohol gas detector	ST / LW / E3 / S3
S2155PR-LD	Propane gas detector	ST / LW / E3 / S3	S2155IN-LD	Iso pentane gas detector	ST / LW / E3 / S3
S2155BU-LD	Butane gas detector	ST / LW / E3 / S3	S2155IP-LD	Iso propyl alcohol gas detector	ST / LW / E3 / S3
S2155VB-LD	Petrol vapours gas detector	ST / LW / E3 / S3	S2155MT-LD	Methyl alcohol gas detector	ST / LW / E3 / S3
S2155AA-LD	Acetic acid gas detector	ST / LW / E3 / S3	S2155MK-LD	Methyl ethil ketone gas detector	ST / LW / E3 / S3
S2155AT-LD	Acetone gas detector	ST / LW / E3 / S3	S2155NN-LD	Nonane gas detector	ST / LW / E3 / S3
S2155AB-LD	Butyl acetate gas detector	ST / LW / E3 / S3	S2155PE-LD	Pentane gas detector	ST / LW / E3 / S3
S2155BT-LD	Butyl alcohol gas detector	ST / LW / E3 / S3	S2155PP-LD	Propylene gas detector	ST / LW / E3 / S3
S2155CE-LD	Ciclohexane gas detector	ST / LW / E3 / S3	S2155PN-LD	Propyl alcohol gas detector	ST / LW / E3 / S3
S2155CP-LD	Ciclopentane gas detector	ST / LW / E3 / S3	S2155TM-LD	Tri-methylbenzene gas detector	ST / LW / E3 / S3
S2155EN-LD	Ethane gas detector	ST / LW / E3 / S3	S2155TO-LD	Toluene gas detector	ST / LW / E3 / S3
S2155AE-LD	Ethyl acetate gas detector	ST / LW / E3 / S3	S2155XI-LD	Xylene gas detector	ST / LW / E3 / S3
S2155ET-LD	Ethyl alcohol gas detector	ST / LW / E3 / S3	S2151AC-LD	Acetylene gas detector	ST / LW / E3 / S3
S2155EE-LD	Ethyl ether gas detector	ST / LW / E3 / S3	S2155AM-LD	Ammonia gas detector	ST / LW / E3 / S3
S2155EL-LD	Ethylene gas detector	ST / LW / E3 / S3	S2155BZ-LD	Benzene gas detector	ST / LW / E3 / S3
S2155EP-LD	Heptane gas detector	ST / LW / E3 / S3	S2155OE-LD	Ethylene oxide gas detector	ST / LW / E3 / S3
S2155ES-LD	Hexane gas detector	ST / LW / E3 / S3	S2154P8-LD	JP8 gas detector	ST / LW / E3 / S3
S2155H2-LD	Hydrogen gas detector	ST / LW / E3 / S3	S2155ST-LD	Styrene gas detector	ST / LW / E3 / S3
			S2155AV-LD	Vinyl acetate gas detector	ST / LW / E3 / S3

Mechanical drawings

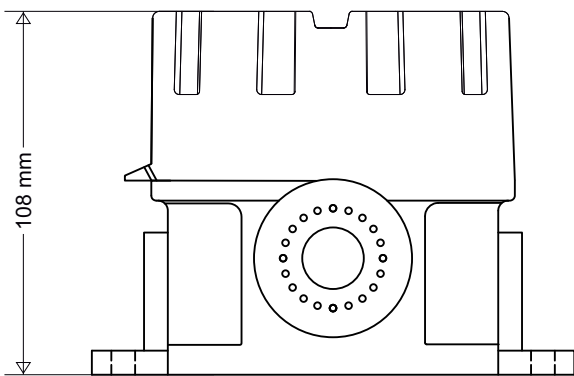

STG/AD3
Dust adapter

