

# SMART3G-C2-LD

with infrared sensor

The SMART3G-C2-LD gas detector is designed to meet industrial requirements; the enclosure is explosion proof and can be installed in ATEX Zone 1 and, when equipped with dust adapter, in Zone 21.

The sensing element is placed in the stainless steel head with a 48 mm diameter. The infrared sensors employed for the flammable and refrigerant gas detection are poison free, with high accuracy and a long lifetime.

The gas detector has a 12-24 Vdc power supply and a standard 4-20 mA 3-wires output and three relays. Optionally, the SMART3G-C2-LD can be equipped with serial RS485 communication.

The aluminium enclosure has dimensions 145 x 187 x 108 mm. The enclosure has 3 cable entries 3/4" NPT threaded. The multi-color LED light ring assures an immediate visual indication of the detector status.

The gas detector can be ATEX marked as follows:

CE 0722 Ex II 2G Ex db IIC T5 Gb

Or, when equipped with dust adapter:

CE 0722 Ex II 2GD Ex db IIC T5 Gb  
Ex tb IIIC T5 T100°C Db  
IP65

The gas detector is IECEx compliant and can be marked as follows:

II 2G Ex db IIC T5 Gb

Or, when equipped with dust adapter:

II 2GD Ex db IIC T5 Gb  
Ex tb IIIC T5 T100°C Db  
IP65

SMART3G-C2-LD is SIL2 hardware and SIL3 software; with a redundant system also the hardware is SIL3.



## Sensor

Application	Industrial area, ATEX Zone 1 and Zone 21 (when equipped with dust adapter, optional)
Sensing element	Infrared
Predicted sensor lifetime	>5 years
Gas detected	Flammable, refrigerant and CO <sub>2</sub>
Fullscale	0 - 100% LFL flammable gas 0 - 2000 ppm refrigerant gas 0-2%Vol; 0-5%Vol; 0-30%Vol; 0-100%Vol CO <sub>2</sub>

## Electrical data

Power supply	12-24 Vdc
Output	Analogue 4-20 mA output; 3 relay board; serial RS485 output (optional)
Maximum dissipated power	5.4 W
Relays contact ratings	1.0 A at 30 Vdc
Optical indications	Multi-color LED light ring
Acoustic indications	-

## Environmental conditions

Storage temperature	-40 / +85°C
Operating temperature	-40 / +60°C *
Operating humidity	20 / 90% RH @40°C *
Operating pressure	80 / 120 kPa *
Air velocity	6 m/s *
Time of response	t <sub>90</sub> < 60 s ; t <sub>50</sub> < 20 s *

\* Data tested with tests described in EN 60079-29-1 standard

## External case

Material	Enclosure: aluminium pressure die-casting with epoxy paint chromating and chemically resistant Sensor head: stainless steel
Protection mode	Ex d : Explosion proof enclosure Ex t : Equipment dust ignition protection by enclosure (when equipped with dust adapter, optional)
Dimensions	145 x 187 x 128 mm
Weight	1900 g
Cable entries	3 x 3/4" NPT
IP grade	IP65

## Compliance

EMC	EN 61000-6-3:2007 + A1:2011; EN 50270:2015
ATEX	ATEX directive 2014/34/UE EN IEC 60079-0:2018 EN 60079-1:2014 EN 60079-31:2014 EN 60079-29-1:2016
IECEX	IEC 60079-0:2011 IEC 60079-1:2014 IEC 60079-31:2013
SIL	EN 61508:2010 Parts 1, 2, 3, 4, 5, 6, 7 EN50402:2017

# SMART3G-C2-LD

with infrared sensor

## Product codes

## ATEX code

Flammable gas detectors 0-100% LFL, 12-24 Vdc

S2624ME-LD	Methane detector	ST / LW / E3 / S3
S2654BU-LD	Butane detector	ST / LW / E3 / S3
S2654PR-LD	Propane detector	ST / LW / E3 / S3
S2654GP-LD	LPG detector	ST / LW / E3 / S3
S2654AT-LD	Acetone detector	ST / LW / E3 / S3
S2654BN-LD	Butadiene detector	ST / LW / E3 / S3
S2654CE-LD	Cyclo hexane detector	ST / LW / E3 / S3
S2654DT-LD	Dimethyl ether detector	ST / LW / E3 / S3
S2654EN-LD	Ethane detector	ST / LW / E3 / S3
S2654AE-LD	Ethyl acetate detector	ST / LW / E3 / S3
S2654ET-LD	Ethyl alcohol detector	ST / LW / E3 / S3
S2654EP-LD	Heptane detector	ST / LW / E3 / S3
S2654ES-LD	Hexane detector	ST / LW / E3 / S3
S2654IB-LD	Iso butane detector	ST / LW / E3 / S3
S2654IL-LD	Isobutylene detector	ST / LW / E3 / S3
S2654IP-LD	Iso propyl alcohol detector	ST / LW / E3 / S3
S2654PE-LD	Pentane detector	ST / LW / E3 / S3
S2654PP-LD	Ppropylene detector	ST / LW / E3 / S3
S2654DE-LD	R152a Difluoroethane detector	ST / LW / E3 / S3
S2654R454B-LD	R454B detector	ST / LW / E3 / S3
S3425R32-LD	R32 Difluoromethane detector	ST / LW / E3 / S3

S3429R1234YF-LD	R1234yf detector	ST / LW / E3 / S3
S3433R1234ZE-LD	R1234ze detector	ST / LW / E3 / S3

Refrigerant gas detectors 0-2000 ppm, 12-24 Vdc

S3944R32-LD	R32 detector	ST / LW / E3 / S3
S3596R134A-LD	R134a detector	ST / LW / E3 / S3
S3599SF6-LD	SF6 detector	ST / LW / E3 / S3
S3656R125-LD	R125 detector	ST / LW / E3 / S3
S3657R1234YF-LD	R1234yf detector	ST / LW / E3 / S3
S3948R1234ZE-LD	R1234ze detector	ST / LW / E3 / S3
S3658R404A-LD	R404A detector	ST / LW / E3 / S3
S3659R407A-LD	R407A detector	ST / LW / E3 / S3
S3920R407F-LD	R407F detector	ST / LW / E3 / S3
S3923R449A-LD	R449A detector	ST / LW / E3 / S3
S3660R507-LD	R507A detector	ST / LW / E3 / S3
S3017R410A-LD	R410A detector	ST / LW / E3 / S3
S3952R417A-LD	R417A detector	ST / LW / E3 / S3
S3956R448-LD	R448 detector	ST / LW / E3 / S3

Carbon dioxide gas detectors, 12-24 Vdc

S2651CO2-LD	CO <sub>2</sub> detector, 0-2% vol.	ST / LW / E3 / S3
S2652CO2-LD	CO <sub>2</sub> detector, 0-5% Vol.	ST / LW / E3 / S3
S2445CO2-LD	CO <sub>2</sub> detector, 0-30% Vol.	ST / LW / E3 / S3
S2630CO2-LD	CO <sub>2</sub> detector, 0-100% Vol.	ST / LW / E3 / S3

## Mechanical drawings

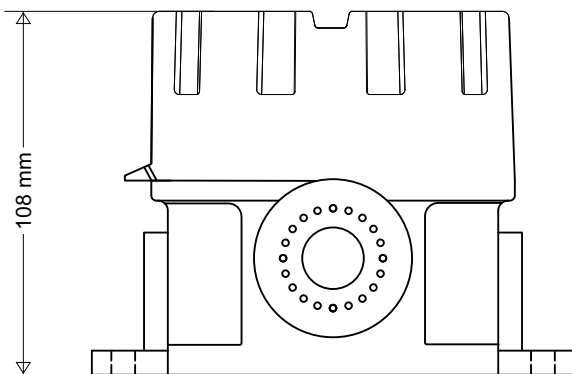

STG/AD3  
Dust adapter

