

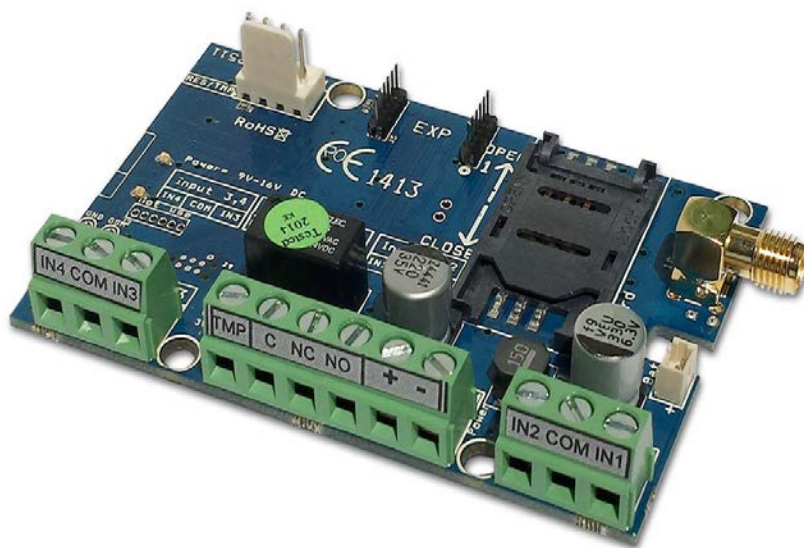

# ProCon GSM

PROFESSIONAL GSM/GPRS TRANSMITTER



INSTALLATIONAL AND USER'S GUIDE

## Table of contents

<b>Device description and function</b> .....	<b>3</b>
Figure 1: Device operation.....	3
<b>Module buildup</b> .....	<b>4</b>
Figure 2: the buildup of the module.....	4
Figure 3: wiring diagram series terminal.....	4
Figure 4: Inserting the SIM card.....	4
<b>Installation guide</b> .....	<b>5</b>
Technical parameters.....	5
Installation steps.....	5
LED signals.....	6
<b>Connecting the module (PC)</b> .....	<b>6</b>
Establishing connection using a USB adapter.....	6
Establishing connection using a Bluetooth adapter.....	7
<b>Programming using the PC software</b> .....	<b>7</b>
Connecting process.....	8
Program buildup.....	8
Checking module status.....	9
Switching off PIN code request on SIM card.....	9
Event Log Readout.....	10
Readout of GSM signal strength.....	10
Fill out basic data.....	10
Saving phone numbers for notification.....	11
Saving controlling phone numbers.....	11
Input configurations.....	12
Figure 5. Normally Open (NO) and Normally Close (NC) wiring.....	12
Voice message settings.....	13
Adjusting outputs.....	14
Tamper settings.....	15
Power supply monitoring setup.....	15
Life signal sending setup.....	15
Anti Jammer System (AJS) settings.....	16
SMS notification of arming/disarming.....	16
GSM alarm center expansion panel.....	17
Figure 7. Alarm center expansion card wiring diagram.....	17
Remote surveillance settings (voice call).....	17
Using your own signal (Contact ID) codes.....	17
GPRS settings.....	18
Other settings options.....	18
<b>Androread</b> .....	<b>19</b>
Connecting to the module.....	19
The menu tree.....	19
Caller ID/Module status.....	20
<b>Programming with SMS commands</b> .....	<b>20</b>
Command List.....	20
SMS command examples.....	21
<b>GSM gate control compact view</b> .....	<b>23</b>

## Device description and function

The GSM/GPRS device can be used for remote controlling (ex.: gate opener), as an accessory to alarm centers and also as a standalone alarm center. The module has 4 contact driven inputs and one implemented relay output (relay type: NO/NC). The module can be expanded with further outputs and functions.

It can send notification to 8 phone numbers in SMS and/or voice message. The notification sending can be triggered by a signal arriving to any of the 4 inputs, by power failure, by sabotage or by arming/disarming of the GSM module. The notifications can be accompanied by an additional voice message that will be played when calling is answered. These recordings can be 8 seconds utmost. The voice message can be also a shared identifying message with a maximum length of 15 seconds.

Output control can be made from unlimited phone numbers with a free call. When controlling with caller identification numbers can be stored in the memory of the module (1,000 in this case), or on the SIM card inserted. With caller identification unauthorized controlling of the device connected to the output is not possible.

Output can be controlled also with SMS command that might even contain differing order from stored settings (ex. output set to bistable can be controlled for 10 seconds). You can find more information on this command on page 20.

DTMF controlling was implemented thus GSM module outputs can be controlled separately with mobile phone buttons. This mode has the condition to accept the call arriving to the module that involves call charges depending on the carrier.

The module can store up to 16,000 events in which appear states of the inputs and outputs, power supply resets, GSM network and module state related information, incoming and outgoing calls and SMSs.

The tamper input on the module can be used as a sabotage indicator with setting possibilities alike to inputs. Shortening it before powering on then cut short in 3 seconds functions as a "reset" that can revert the module back to its original factory state.

Implemented Anti Jammer System (AJS) protects from GSM jammers. The significant dropping of the GSM strength or a network connection failure initiates a prompt alarm. In these situations module tries to send notifications using network possibilities still available. It can be set that by controlling the output even a siren can be managed. This possibility is especially useful if we would like to fob the person who committed the sabotage.

As a standalone alarm center 4 zones can be distinguished and they can have Contact IDs or zone codes. The types of the inputs can be altered based on that (ex. 24/7, delayed etc.). By using expansion panel (EXP Alarm) an LED status feedback is available of the armed/disarmed module status and also the control of a peripheral buzzer in case of arming disarming and alarm event.

Besides continuous voltage monitoring the module observes also the GSM strength. These data can be readout and these can be charted even by hourly divisions by the programming and surveillance software.

By using expansion panels further outputs (EXP Relay, EXP Relay3), or expansion panel for standalone GSM alarm center (EXP Alarm) can be connected

The module can be programmed by SMS command, voice menu, PC or by Android mobile phone.



Figure 1: Device operation

# Module buildup

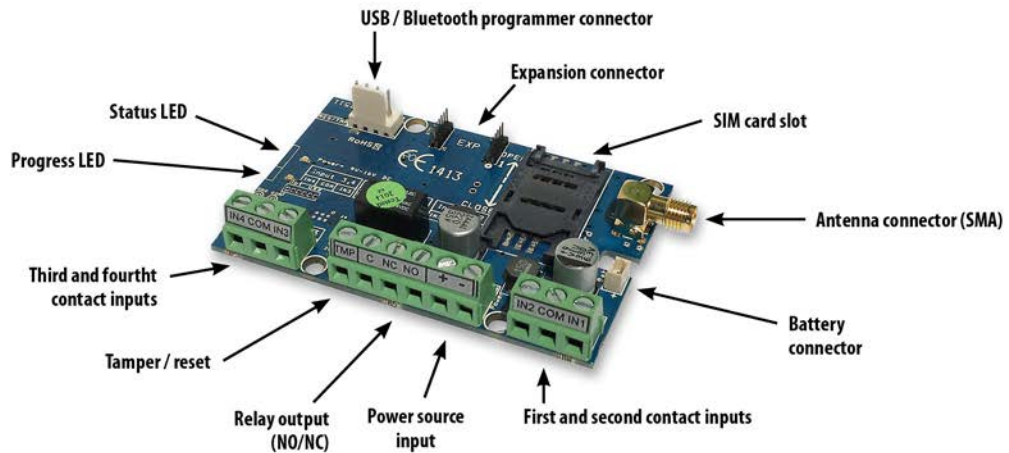

Figure 2: the buildup of the module

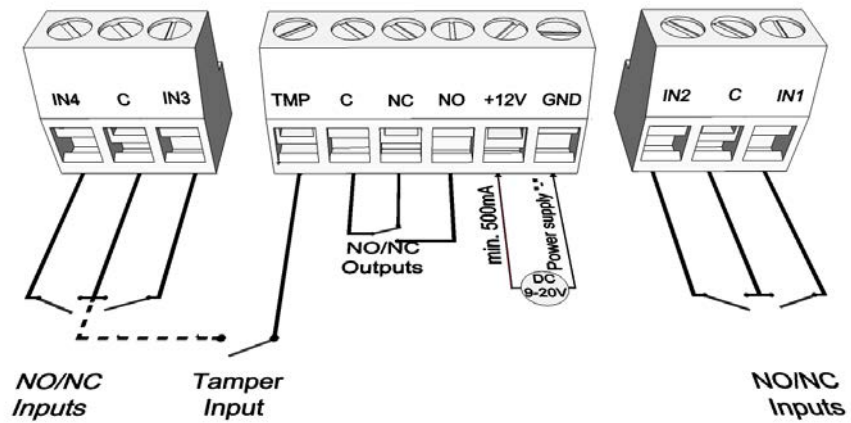

Figure 3: wiring diagram series terminal

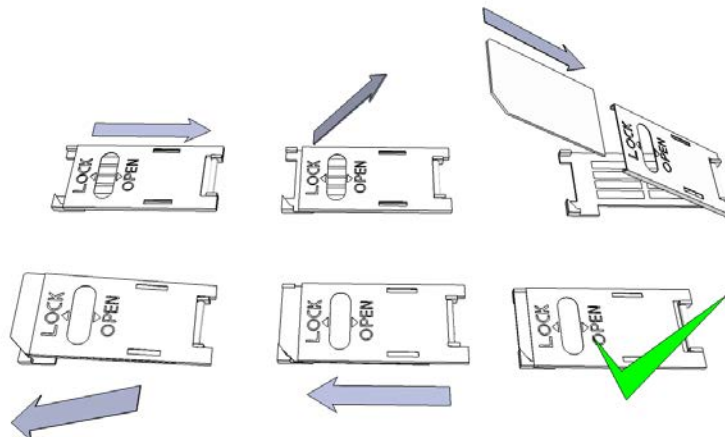

Figure 4: Inserting the SIM card

# Installation guide

## Technical parameters

- Power voltage: 9-20 VDC
- Standby power drain: 30 mA
- Maximum power drain: 700 mA
- Relay output load: max. 20V / 500 mA
- GSM module type: SIMCOM 900
- GSM frequencies: GSM 850 / EGSM 900 / DCS 1800 / PCS 1900 (Multi- Band)
- SIM card usage: brand free GSM module
- GSM antenna type: SMA connector (comes with package)
- Size: 78 x 51 x 20 mm, packed: 132 x 128 x 32 mm
- Operation temperature: -20°C - +50°C

## Installation steps

1. Carry out a signal strength check with your mobile phone. Sometimes occurs there is no sufficient signal strength at the commissioning site. In this case it is recommended to change the module position prior to installation. Do not install the device to places where strong electromagnetic waves might occur, ex. next to electric motors or alarm transformers.
2. Do not install in watery places or to places with great humidity.
3. Connect the antenna that can be secured with an SMA connector. If you are reading low signal strength use antenna with higher gain. Signal strength grow can also be achieved by repositioning the antenna. **Do not position the antenna under various metal covers as those might significantly ruin the signal strength.**
4. **You should opt out the PIN number request, voicemail and call notification of the SIM card.** Sometimes new SIM cards must be activated (usually one outgoing call has to be made). Check the validity of the card. If you have a prepaid card check its balance and its usage possibilities (ex. can be used only for calls).
5. Number identification of caller and at call initiations has to be checked. This function at certain service providers. Must be enabled formerly.
6. Insert the SIM card in the SIM card slot of the module.
7. Connectors have to be connected according to the wiring diagram. If you are dealing with OC output (output of EXP Alarm expansion panel) mind the correct wiring of the relay protecting diode.
8. If you are working with OC relay be cautious especially of avoiding electric shock. A proper contact protection must be established. If you lack the appropriate experience ask for professional help.
9. Check if the power supply performance will be sufficient for the module. Mind the polarity. If wiring is reversed the module will not operate or might get damaged.
10. Now the device can be connected to the power supply.
11. If you have purchased also a battery connect it to the device. **Use only the appropriate battery for reserve powering the device!**
12. After connecting the voltage supply the red LED is lighted indicating the device establishing connection with the **GSM system (this can be 1 minute utmost).**
13. If red LED goes off and green LED flashes module is online and connected to network. The **flash number(s) indicates GSM signal strength.**

**For programming the power supply must be connected! Power needed for programming can be supplied to the module also from USB adapter.**

## LED signals

Signals give essential information of the module, of GSM signal strength and the actual error codes. By blinking we mean flashes between two longer pauses.

- A STATUS LED (green) gives feedback of signal strength value based on the chart below:

Flashes	Signal quality
1	Bad
2	
3	Decent
4	Good
5	Excellent
LED lighted	GSM connection rejected

- An ACT LED (red) lit means the initiation process at startup. At this phase module performs the initial checks. During operation this reflects an event (SMS or voice call).
- If the red and green LED are lighted simultaneously it tries to communicate an error that can be identified with the chart below:

Flashes	Error code
1	Initializing
2	Bad GSM module
3	SIM card not inserted
4	SIM card locked with PIN code
10	Modem mode

- Alternating flashes of red and green LEDs means the "reset" function of the tamper input. This way the GSM module can be reverted back to its original factory settings.
- To switch-off the **modem mode**, open the **module status** window in the **Services menu**.

## Connecting the module (PC)

### Establishing connection using a **USB adapter**

1. Connect the USB adapter to the *Program* labeled slot of the module.
2. USB adapters can provide the sufficient voltage for programming the GSM module.
3. Attach the USB connector of the adapter to a USB extension cable and plug into any USB port of a PC.
4. **WARNING! If you are using Windows Xp operating system** the system offers an automatic driver installation. IMPORTANT, do not use the offered driver but carry on the installation with the **USB driver**.

#### Installing the USB driver manually in 10 steps

- ✓ get the required driver from our web site or from the "USB driver" directory on the CD if you have the USB Kit
- ✓ use the appropriate 32 or 64 bit version for your operating system in the installation process
- ✓ to check this use the Control Panel → System menu path (when using Windows XP "x64 Edition" will only appear if the system is running on 64 bit)
- ✓ connect the USB programmer to your PC
- ✓ do not chose the automatic installation offered by the system
- ✓ Open the path Control Panel → System → Hardware **Device Manager** window.
- ✓ In this window search for **Unknown device** (which will be the programmer now, later the **USB Serial port**). If you cannot find it start the "Scan for hardware changes" process from the upper window menu.
- ✓ Device properties can be achieved by double clicking on the unknown device.



- ✓ Start the Update driver process
- ✓ In the installation window choose the manual selection of the driver location then choose the appropriate folder containing the 32 or 64 bit driver
- ✓ Click on the Next button to start the installation.

5. Open the Device Manager (click on System → Properties → Hardware tab → Device manager)
6. Search for a device named USB Serial port (COM...) under Ports
  1. If a driver reinstall is needed click on the device then choose driver removal then follow instructions above.
7. Start the programming software.
8. You have to set the value in brackets [USB Serial port (COM...)] in the programming software
9. Establish a connection to the GSM module.

**Establishing connection using a Bluetooth adapter**

1. Connect the Bluetooth adapter to the GSM module and provide power to it.
2. Switch on the Bluetooth connection possibility on your device (PC or Android mobile phone).
3. Search for programmer with the help of your Bluetooth enabled device.
4. After finding the adapter you can pair your PC/smart phone with the adapter using the code “1234”.  
**Search for the COM port number of the connection (usually under Properties → Hardware tab)**
5. Search for the COM port number of the connection (usually under Properties → Hardware tab)
6. Set the port number also in your programming software (PC) or choose the automatic port finding option.
7. Establish a connection to the GSM module.

**If you use Windows 8 operating system the programming software should be started in “Windows XP SP2/SP3” compatibility mode (Right click on the starting icon of the program → Properties → Compatibility)**

In every case you can check the connection if you see the connected module name next to the Start button in the programming software and the green LED on the programmer starts to flash.

**If you have a connection established between the adapter and your PC or mobile phone you can start the module configuration.**

- **By clicking the Start button after the connection was established modules settings will be acquired.**
- **By clicking the Start/Default config button (after a confirmation) it will revert back the module to factory settings.**
- **Using the Android application settings are always acquired after establishing a connection.**

**Programming using the PC software**

- If you have chosen configuration by PC you can use our software that is freely downloadable from our website or you can find it on the installation CD in the USB KIT.
- The program runs automatically, no installation needed
- Compatible with operating systems Windows XP, 7 and 8
- Make sure you always use the latest software!
- If newer software is out the module should be updated prior to the first configuration.

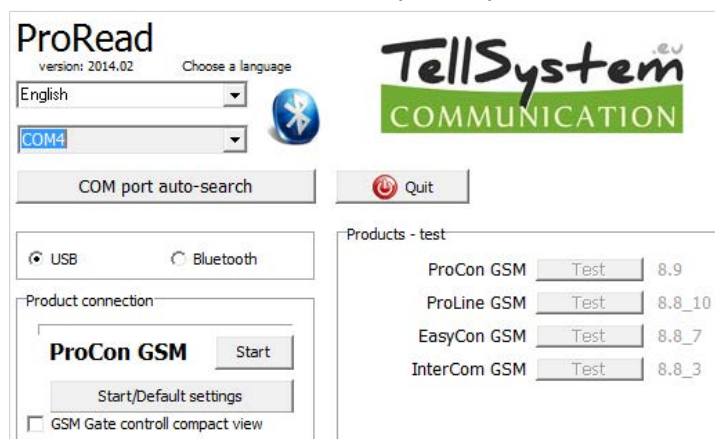

## Connecting process

- To program the module choose between USB or Bluetooth connection.
- Below the language selection in the scroll down list (COM 4 in the picture) you can select the port through which you would like to communicate with the module programmer. You can find this value (in Windows operating system) under Device manager → Com port at the connected programmer. If you cannot decide you might let the program to search for it by pressing the **automatic COM port finding**. The automatic COM port search might take several minutes.
- If the connection was successful you will see under the Product connection tab the name of the module.
- Clicking the **start** button the software connects to the module and reads out its settings.
- By clicking the **Start/Default config** button the module will be set back to default factory settings after the connection was established. (Before the operation the software asks for confirmation if this feature has not been switched off before).
- If you do not want to attach a module just to inspect the settings options you can select the **Products-tryout** window where you can freely make a specific module properties selection and also module preprogramming.

## Program buildup

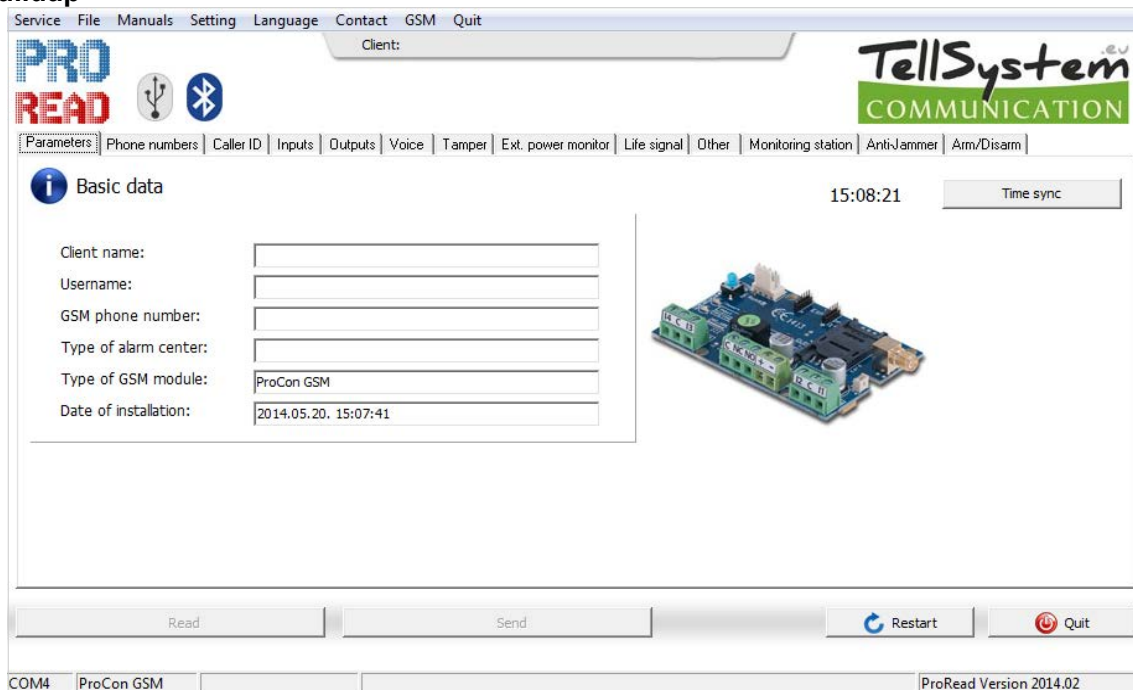

- Upper menu items:
  - Maintenance: basic menus needed for module maintenance (for ex. module state check, event log readout, PIN code request switch off of the SIM card, Firmware upgrade)
  - File commands: Saving and loading settings
  - Descriptions: viewing wiring diagram
  - Settings: setting window size, switch off confirming dialogs
  - Language: language selection (available languages: English, Hungarian, Italian, German, Slovak, Slovenian, Dutch, bohemian, Finn, Romanian)
  - Contact: our contacts; e-mail addresses and phone numbers
  - GSM: reverting back to factory settings the GSM chip (SIM900 chip) and auxiliary PSTN line monitoring (in case of a failure), providing GSM information, saving central SMS number of the network operator
- You can reach the various settings of various items by clicking the appropriate tab
- On the main page (**Basic data** tab) clicking the **Clock Synchronization** makes the module to adjust its time to the PC clock.
- After the device established a connection with the mobile network it will automatically adjust the time with the



mobile network (if this feature is available).

- The **Reading** and **Sending** buttons at the bottom are for readout and edit of the module configuration. These buttons are accessible everywhere except on the **Controlling phone numbers** tab. You should send data to the module with the **Send** button after every significant modification. Before sending your settings make sure those will not trigger an unexpected alert. You should readout the actual module state beforehand (**Maintenance** tab).  
**WARNING! After connection always readout the settings first if you would like to alter those.**
- You can restart the module with the Restart button. After monitoring is complete the module should be restarted.
- In the lower menu line you can be informed of the followings:
  - Communication port number
  - GSM module name
  - Firmware version number
  - Notification on the actual software process
  - ProRead version number

### Checking module status

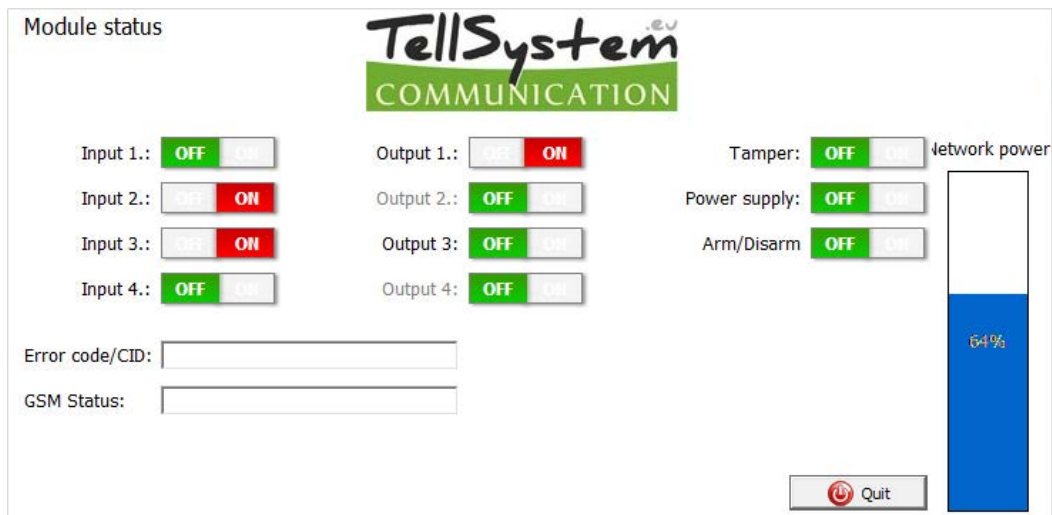

You can reach the actual status through **Maintenance** → **Show module status** button

By the module status query you will be informed of the followings:

- input statuses
- output statuses
- Tamper sabotage notification
- power supply failure notification
- armed/disarmed module status
- displaying occurring error/event codes (ex.: no SIM card inserted, SIM card locked by PIN code)
- checking Contact ID code (to monitoring station) sending process (ex. handshake status)
- GSM connection status (ex. connected to the network, roaming, no connection, connection rejected)
- actual GSM signal strength (refreshing in seconds)

### Switching off PIN code request on SIM card

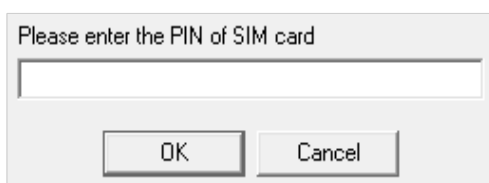

Before inserting SIM card in the module the **PIN code request should be switched off**

- If you have not done yet then you can switch off at **Maintenance** → **Switch off PIN code request**.
- You will see the following window, where you can input the code and its request will be switched off.

Event Log Readout

EVENT	DATE	GSM 0-31	GSM Network	Note / parameters	
61	GSM logged	2014.04.30. 14:22:43	18	Connected	IMEI:861785007544749 SIM:08.8
62	Voice MENU enter	2014.04.30. 14:19:45	11	Connected	USER/
63	Ext. power monitor	2014.04.30. 14:19:34	15	Connected	Restore
64	Incoming calls rejected	2014.04.30. 14:19:33	15	Connected	
65	GSM logged	2014.04.30. 14:19:32	15	Connected	IMEI:861785007544749 SIM:08.8
66	Ext. power monitor	2014.04.30. 14:16:21	14	Connected	Restore
67	Incoming calls rejected	2014.04.30. 14:16:31	14	Connected	
68	Input 1.	2014.04.30. 14:12:58	0	Not connected	
69	Input 1.	2014.04.29. 15:42:52	31	Connected	Restore
70	OUT call (successful)	2014.04.29. 15:42:15	31	Connected	+36308993618
71	Input 1.	2014.04.29. 15:42:11	31	Connected	
72	Input 1.	2014.04.29. 15:39:52	25	Connected	Restore
73	OUT call (successful)	2014.04.29. 15:39:26	31	Connected	+36308993618
74	Input 1.	2014.04.29. 15:39:14	31	Connected	
75	Ext. power monitor	2014.04.29. 15:36:41	31	Connected	Restore
76	GSM logged	2014.04.29. 15:36:41	31	Connected	IMEI:861785007544749 SIM:08.8
77	OUT call (successful)	2014.04.29. 15:36:46	31	Connected	+36308993618
78	Input 1.	2014.04.29. 15:36:36	31	Connected	
79	Incoming SMS	2014.04.29. 15:37:16	31	Connected	+36308993618/RTTEL:0036304500919
80	OUT call (successful)	2014.04.29. 15:36:09	31	Connected	+36308993618
81	Input 1.	2014.04.29. 15:36:00	31	Connected	
82	Input 1.	2014.04.29. 15:36:00	31	Connected	Restore
83	Incoming SMS	2014.04.29. 15:55:51	31	Connected	+36308993618/PV.ID: V1.4TEL: 0036304500919
84	OUT call (successful)	2014.04.29. 15:54:19	31	Connected	+36308993618
85	OUT call (successful)	2014.04.29. 15:53:22	31	Connected	+36308993618
86	Input 1.	2014.04.29. 15:53:17	31	Connected	
87	Input 4.	2014.04.29. 15:53:03	31	Connected	
88	Ext. power monitor	2014.04.29. 15:53:03	31	Connected	Restore
89	Input 4.	2014.04.29. 15:53:03	31	Connected	Restore
90	Incoming SMS	2014.04.29. 15:53:03	31	Connected	+36308993618/Text: SMSW:08.8
91	Input 1.	2014.04.29. 15:41:46	0	Not connected	
92	Microcontroller START(IMEI:2011.01.01. 00:00:57	0	Not connected		
93	Microcontroller START(IMEI:2011.01.01. 00:00:57	0	Not connected		
94	Open (GSM)	2014.04.25. 08:20:48	31	Connected	+36304500919

The event log can be viewed by clicking **Maintenance** → **Read Event Log** button:

- It can store up to 16,000 events in FILO (first in-last out) mode
- The acquired list can be saved in "csv" file for later examination. This can be done also in the event list by clicking the "Open csv" button.
- In the **Token** column there are short event information.
- In the **Date** column notification dates are stored. IMPORTANT! Date will be accurate if the clock of the module is synchronized with a PC or with GSM system. The latter is automatically done by the module when connected to the network of the operator.
- The **GSM 0-31** indicates the signal strength at the time of creation. 31 is the highest, 0 indicates state with no connection.
- Network indicates if the module was connected to the network carrier at the time of creation.
- In the **Comment/parameter** column notification related extra information are stored.
- Initially the chart is empty; the readout can be commenced by pressing the **Readout event log** button.
- The newest data will appear at the top of the list followed by older entries as you go down the chart.
- If the whole chart readout is not necessary you can stop it with the **Readout stop** button.
- Read out list can be exported from the software in "csv" (ex. Excel) chart so later it can easily be sent and stored.

Readout of GSM signal strength

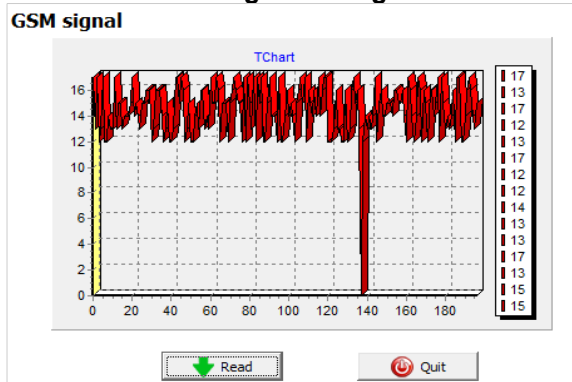

The chart of GSM signal strength is available by the **Maintenance** → **Show GSM signal strength** button

- You can have the values by pressing the **Readout** button
- Measured readings can be displayed by clicking the "Reading" button.
- Signal strength fluctuations are divided by hours. Passed time should be interpreted according to this.
- Vertical scale is calibrated from 0 to 31. 31 mean the best signal strength.
- Size of the chart can be freely altered by left click.

Fill out basic data

**i** Basic data

Client name:

Username:

GSM phone number:

Type of alarm center:

Type of GSM module:

Date of installation:

Important data of the installed GSM module can be set. Besides the client name and commissioning address the phone number of the SIM card inserted in the module and the type of the attached alarm center also can be set.

- Data inserted are stored in the module
- Stored data can be useful later during maintenance.

### Saving phone numbers for notification

- In the phone number tab you can set those phone numbers to which SMSs and/or voice messages will be sent
- **Numbers given in this section must be in international format to ensure safe operation.**  
(Ex.:+36301234567 or 0036301234567)
- For notification maximum 8 phone numbers can be set.
- You can select these numbers in the following program section.
- This list can be edited also by SMS with the "TELx= phone number" command, where 'x' represents the ordinal number of the phone number chosen for edition. (Example: 1234TEL1=+36301234567, 1234TEL2=+36304564323) See **page 20** for **SMS commands**.

### Saving controlling phone numbers

- At the Control phone numbers section you can set telephone numbers that can control the outputs.
- Phone numbers can be stored in the memory of the module (maximum 1,000 pcs). Moreover, additional phone numbers can be stored in the SIM card. The phone numbers on the SIM card memory can be read out only. New phone numbers can be saved to the SIM card if we insert the SIM to a mobile phone and we save the additional numbers.
- By using inner memory the module will be independent from the SIM card memory.
- Always read out the memory before editing the list with the **Readout numbers from memory** button. For saving use the **Save numbers to memory** button, and then the **send** button.
- **Stored numbers must be in international format.** Due to number length using "+" is suggested (ex.: +36301234567).
- Storing, editing and opening of numbers are also possible (from .csv file).
- Control numbers can be associated with specific outputs.
- By choosing DTMF control, the outputs can be controlled with cell phone buttons (1, 2, 3, 4). Module can be armed/disarmed with DTMF command (\*).
- The list can be modified also by **SMS command** with **ADD=phone number** (addition) and **DEL=phone number** (removal) commands
- (Example: 1234ADD=+36301234567, 1234DEL=+36301234567)
- You can find additional information on **SMS commands** on page 20

### Timezona settings

- At the Timezone tab, we can set in which time interval the control of the phone numbers is enabled.
- The timezone function works only with phone numbers in the internal memory.
- Three different time zones can be set with 5 minutes accuracy.
- The desired time interval can be set from a drop-down list next to the phone number list.
- By using **IN4 Disabled**, we can disable the control permission of the phone numbers which are enabled according to the actual timezone.
- By using **IN3 Enable**, we can enable the control permission of the phone numbers which are disabled according to the actual timezone.
- For using the function 9.0.4 or higher software version is necessary.

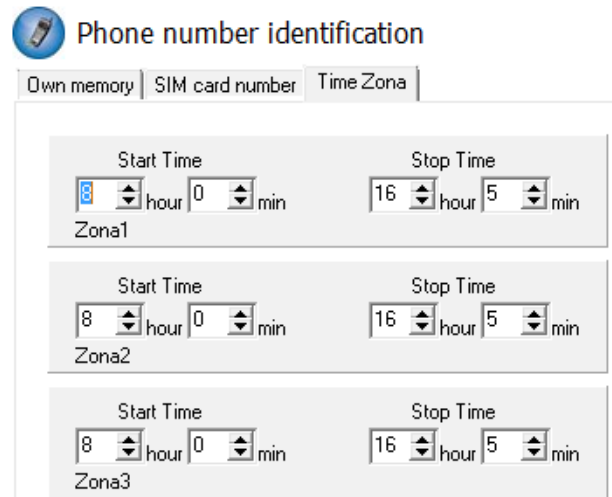

### Input configurations

The GSM module has “dry” contact inputs. Before reviewing settings examine input wiring possibilities in the picture below. The four outputs can have individual settings.

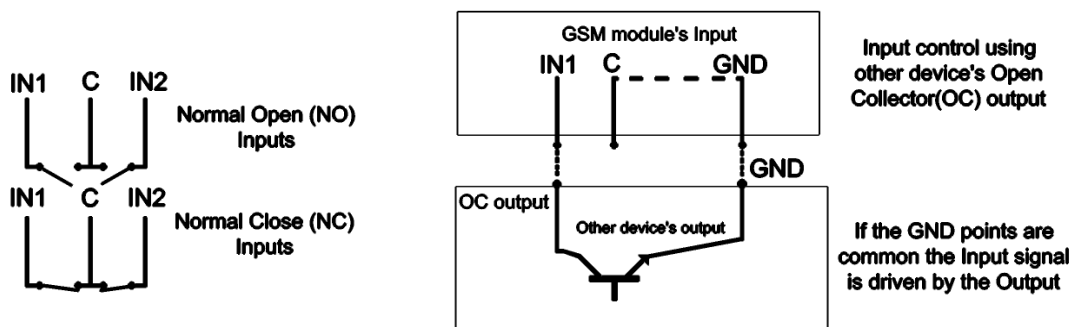
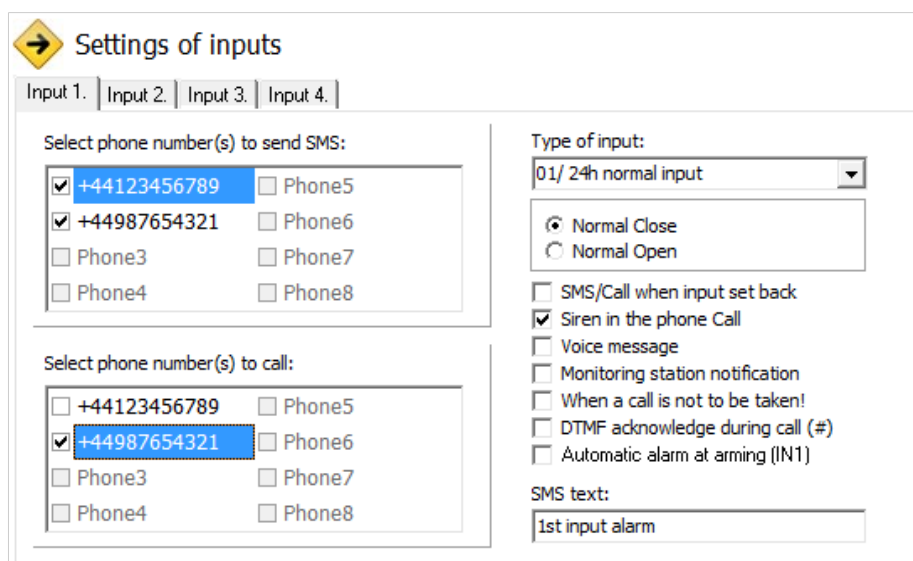

Figure 5. Normally Open (NO) and Normally Close (NC) wiring



You can set on this tab if there is an alarm event caused by short or open circuit on an input to which phone number you

would like to send SMS or voice message notification. It is possible to send both notifications to the same phone number.

- On the **Input type tab** you can set how the input should operate:
  - 00/Not used: not used inputs can be switched off so no jamming signals can be received.
  - 01/24h normal input: 24/7, constant, input indifferent to activation status
  - (02/Backup: not used input left on so it can be used later)
  - 03/Center input: this input will send alert only if the module is activated.
  - 04/delayed center input: in activated state this input starts a countdown (can be set on the “Other” tab) while you have the chance to deactivate it.
  - 05/Arming/disarming: input for arming or disarming the module. This can be controlled only with continuous contact (ex key switch). Normally closed state is suggested so wire cutting will trigger an alarm.
- The input can be set to be normally opened (NO) or normally closed (NC).
- An SMS message can be sent if the input reverts back to its normal state. **This message can be given in the SMS text for input text on the other tab.**
- If **siren sound** is selected as alarm sound voice call duration will be 25 seconds. If also the voice message option is selected its length will be 5 seconds.
- At **voice message** transmission prerecorded or custom sound can be chosen to send with a voice call (**Sounds** tab)
- **Monitoring station** can also be notified of the input state change via voice message.
- You can set a no pickup mode so module will not try to call again if the call was received regardless it was accepted or rejected.
- The first input can be set to send notification if module is powered on. Thus the module indifferent to its state will initiate an alarm event. This function is suggested when you want the module power-on to initiate an alarm event.
- In the **SMS message** box you can set the message that can be **maximum 32 characters** long.
- Input modifications can be achieved by SMS commands with the following parameters:
- **1234INPUT1=tnneeeeeeee**
- t: 0 → switched off 1 → 24h normal 2 → backup 3 → alarm normal 4 → alarm delayed nn → NO or NC eeeeeeee: Other parameters: 1.e=1 → Message of reverting back 2.3=0 → Compulsory 0 3.e =1 → siren sound 4.e=1 → Voice message 5.e=1 → Monitoring station 6.e=1 →no need to pickup at call 7.e=1 → DTMF acknowledge (#) 8.e=0 → Compulsory 0
- **You can find additional information on SMS commands on page 20.**

### Voice message settings

**Upload voice**

Playing the identification message before the event message

Identification: Internal [Upload] [Play] [Stop] [Record]

Input 1: Internal [Upload] [Play] [Stop] [Record]

Input 2: Internal [Upload] [Play] [Stop] [Record]

Input 3: Internal [Upload] [Play] [Stop] [Record]

Input 4: Internal [Upload] [Play] [Stop] [Record]

Power: Internal [Upload] [Play] [Stop] [Record]

Tamper: Internal [Upload] [Play] [Stop] [Record]

Voice format: 8Khz, 8bit, mono, PCM

In the **Sounds** menu a specific alert can be associated with a prerecorded voice message.

- The function of the **identifying message** is to identify the module (ex. address, building name) if you are waiting messages from several modules.
- If you click the **red record** button you can record your own voice with a microphone attached to your PC. This can be up to 8 seconds in length or 15 seconds for the identifying message.
- During voice recording it records from the default microphone. Sometimes it needs to be adjusted (ex. amplify) for the optimal volume and quality.



- By clicking the Play button you can listen to your recording.
- If you would like to upload a prerecorded sound file than you can open a file upload window by clicking the appropriate event button.
- The file format has to be compatible with the format used on GSM networks. It has to be **8 kHz** sampling rate, **8 bit, mono PCM** modulated ".wav" file.

When you have the desired sound it can be uploaded to the module by clicking the Upload button.

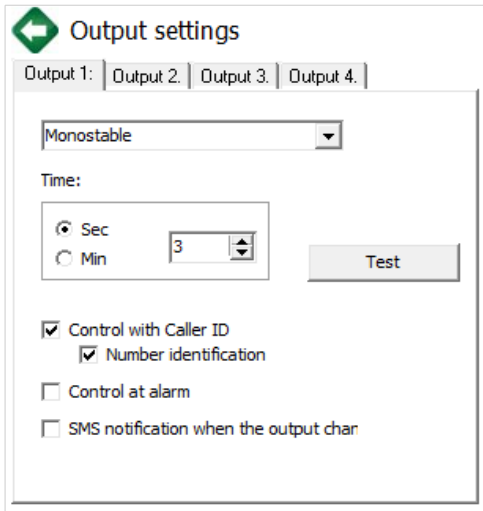

### Adjusting outputs

On the **Output** window the output settings can be changed. The output type can be **monostable** namely one stasured, (switches for the given period than reverts back to the original status), or **bistable** namely two stasured (it only will revert back to original state after a new controlling).

- Regarding monostable operation switch time can be set in seconds or minutes. This can be max 65,000 seconds.
- The **Unsuccessful SMS** means output will be controlled when network operator rejects an SMS sending.
- Choosing **GSM fault** output will be controlled as long as GSM network reverts to its normal state
- Regarding output controlling it can be set if you want to control with incoming call or it should be activated by an alarm event (ex. in case

of 24/7 active input).

- When controlling with caller identification is set you can choose between unidentified or identified phone number control. By assigning the **SMS notification when the output changes** field, we can send SMS message about about the first input change.
- Anybody can control the output with unidentified phone number controll if he/she knows the phone number of the SIM card.
- **If the phone number identification is selected controlling from a controlling phone number not in the list will be denied. This greatly improves module safety regarding unauthorized controlling.p. 21.**



**EXP RELAY**

- **EXP Relay** provides additional 1, **EXP Relay3** provides 3 additional outputs for the GSM module. Thus by using EXP Relay 3 the module can have 4 outputs.
- Only one expansion panel can be connected simultaneously. Expansion panels connect to the Panel labeled slot of the modules.
- Both expansions contain low-voltage relayed output switcher.
- EXP Relay has NO/NC relay, EXP Relay3 has jumper adjustable output for NO or NC version.



**EXP RELAY3**

- Output settings can be modified by sending the following message:
- 1234OUTx→ Selectable parameters: ON, OFF, RUN or switch to a certain time (given in 5 characters)
- example: 1234OUT1=00003 → controlling output 1 for 3 seconds
- You can find more information on **SMS commands** on **page 20**.

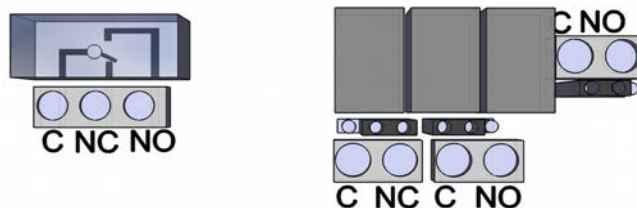
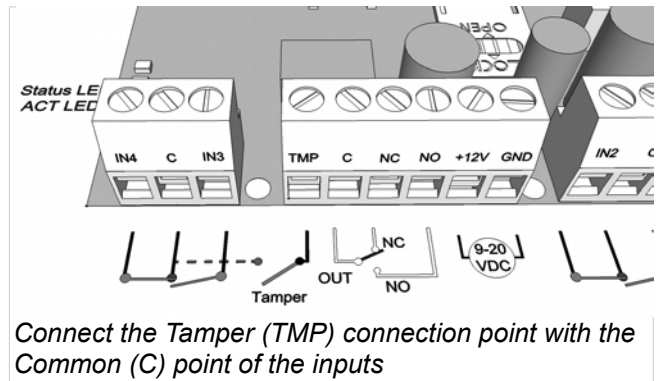

**Figure 6: Exp Relay and Exp Relay 3**

### Tamper settings

The GSM module facilitates the connection of a tamper protection. Essential of this protection is that module will trigger an alarm if GSM case is removed.

- Its connector is next to the first output shared connector of the main panel. Connector usage is similar to input: only suitable for monitoring short or open circuit.
- Connector must be connected according to the wiring diagram. You can use any shared input terminal. DO NOT USE SHARED OUTPUT TERMINAL (C).



**Settings of Tamper**

Select phone number(s) to send SMS:

+44123456789  Phone5  
 +44987654321  Phone6  
 Phone3  Phone7  
 Phone4  Phone8

Select phone number(s) to call:

+44123456789  Phone5  
 +44987654321  Phone6  
 Phone3  Phone7  
 Phone4  Phone8

Type of input: 01/ 24h normal input

Normal Close  
 Normal Open

SMS/Call when input set back  
 Siren in the phone Call  
 Voice message  
 Monitoring station notification  
 When a call is not to be taken!  
 DTMF acknowledge during call (#)

SMS text: Tamper alarm

- Tamper connector settings do not differ from any other input settings. On demand connector can be used as a 5<sup>th</sup> input.
- If you are using tamper for monitoring case removal input type should be set as closed by default.

### Factory reset

Shortening the terminal before powering on than releasing in 3 seconds will revert the GSM module back to its factory settings. This progress is indicated by the alternate flashes of the ACT and STATUS LEDs.

### Power supply monitoring setup

The GSM device is able to monitor its power source and send notification of its problems

- On the **Power monitor** tab the trigger voltage level can be set. Below this the module sends an alert.
- Our Pro series modules have battery connectors that can be used to connect the Pro Battery.
- **IMPORTANT!** Modules without auxiliary power supply will switch off if there is no main power supply.
- The remaining function settings equals with the input settings.

**Settings of Ext. power monitor**

Select phone number(s) to send SMS:

+44123456789  Phone5  
 +44987654321  Phone6  
 Phone3  Phone7  
 Phone4  Phone8

Select phone number(s) to call:

+44123456789  Phone5  
 +44987654321  Phone6  
 Phone3  Phone7  
 Phone4  Phone8

Alarm voltage value: 11V

SMS/Call when input set back  
 Siren in the phone Call  
 Voice message  
 Monitoring station notification  
 When a call is not to be taken!  
 DTMF acknowledge during call (#)

SMS text: Internal power alarm

### Life signal sending setup

**Life signal settings**

Life signal sending

Select phone number(s) to send Life signal messages:

+44123456789  Phone5  
 +44987654321  Phone6  
 Phone3  Phone7  
 Phone4  Phone8

7 Day(s)  
 12 At ... o clock  
 0 First, after ... day(s)

SMS text: Life signal, system OK...

Voice call to the 1st phone number

Test

- By life sign sending the user can be sure about the flawless operation of the system.
- The life sign sending periods and also exact hour can be set for notifications.
- **To use this feature Send life sign check has to be selected!**
- It is also important the day of the first signal can be scheduled not to arrive on the setup day. The life sign activation day can be set.
- You can modify life sign sending with the

- following SMS command: 1234LIFETEST=cccsstttttt

- ccc → sending cycles/days (ex.: 007 days)
- ss → hour of sending on a day
- tttttt → which telephone number will be notified (ex.: 00100000 → it will send the message to the 3<sup>rd</sup> phone number)
- **You can find more information on SMS commands on page 20.**

**Anti Jammer System (AJS) settings**

- By using a GSM jamming device (GSM jammer) the GSM module can be sabotaged by suppressing heavily the signal strength of the network or by its complete suspension. The Anti Jammer System (AJS) is monitoring changes in network signal strength.

- You can set which output you would like to control instantly when there is an Anti Jammer System event. In this situation it will control a peripheral device connected to its output (ex auxiliary siren).

Sending SMS/making voice call can be achieved only if there is still some connection with the network. If there is no connection sending will be completed when network signal is available.

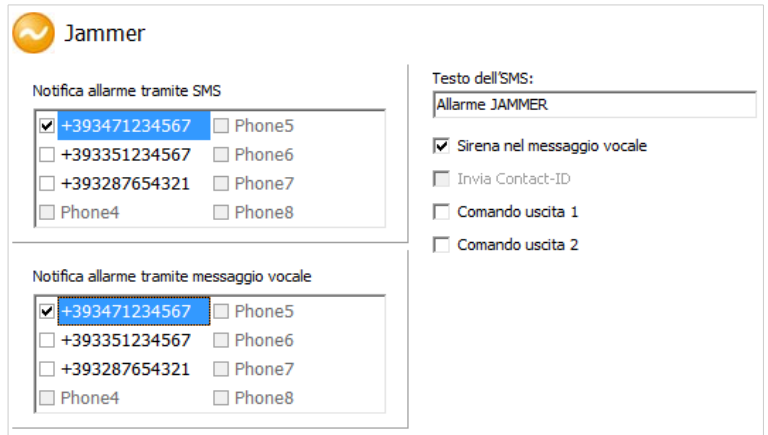

**SMS notification of arming/disarming**

**Settings of Arm/Disarm**

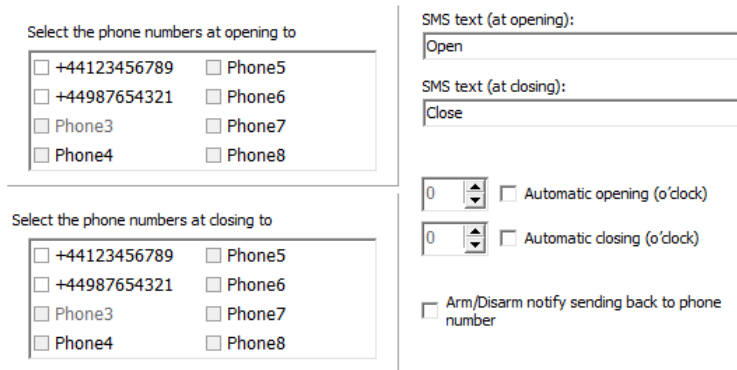

At opening/closing i.e. the state of the module changes between armed/disarmed a notification SMS can be sent.

You can set the SMS message that can be maximum 32 characters long.

- An automatic activation/deactivation time for module can be set. This needs activation and deactivation time.
- Besides to the notified numbers a module status notification SMS can also be sent to the controlling number.

**GSM alarm center expansion panel**

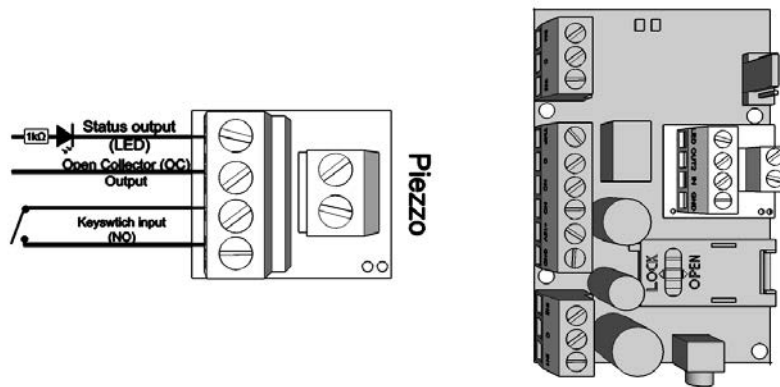
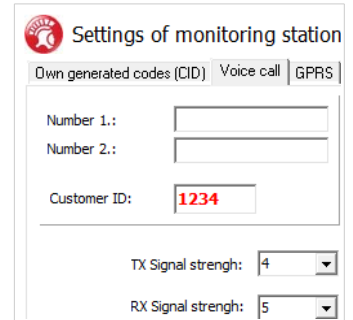
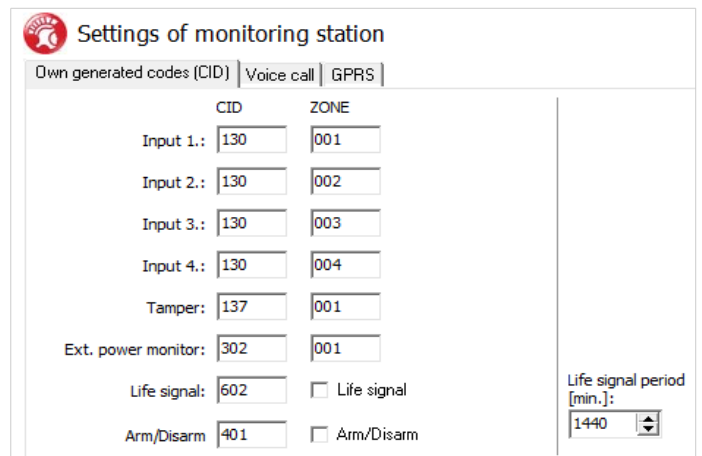

**Figure 7. Alarm center expansion card wiring diagram**

- By using the expansion panel GSM module can be converted to standalone alarm center.
- The expansion panel connects to the slot next to the programmer port according to the position on figure 7.
- Simultaneously only one expansion panel can be attached to the module.
- The alarm center expansion module provides the following new features for the module:
- status output; if you connect an LED to it (using a resistor to control the flowing power) you can have light feedback of the armed module status. When you arm the module the LED starts to flash.
- open collector output that serves as a second output. When it is controlled it will close with the GND of the expansion alarm.
- Extra input through which module can be armed/disarmed by a continuous contact or an impulse (we suggest connecting key switch here)
- Piezzo connecting point; facilitating sound for differentiating exit time (arming state) and alarm

### Remote surveillance settings (voice call)

- Remote surveillance notification can be used side by side with the SMS and voice call notifications. This feature works at more than 50% of signal strength.
- Regarding the order first remote surveillance will be notified than remaining notifications will be processed.
- Two remote surveillance numbers can be set. If there is a connection failure with the first number it will call the second phone number.
- Client code is decided by the remote surveillance. You can use only your own code.
- The communication with the remote surveillance can be improved by changing the signal level of the module transceiver.
- First example: if remote surveillance cannot interpret the code received sender level has to be adjusted
- Second example: if the GSM module during the handshake does not receives accurately reply from remote surveillance the Receiver value has to be modified
- Change the default settings only in case when this is required by the available signal strength or by remote surveillance distinctives.

### Using your own signal (Contact ID) codes

- The module can forward also self generated signals (ex. signals to inputs, power supply failure) to remote surveillance.
- Contact ID and Zone codes can be modified.
- Notification can be revised under the **Maintenance -> Module state display** tab. Here in the error code window sending actual Contact ID is displayed.
- If messages sent are not interpretable signal strength and module antenna position must be checked.
- **The connected antenna should be away from the module and any other electric device or cable!**

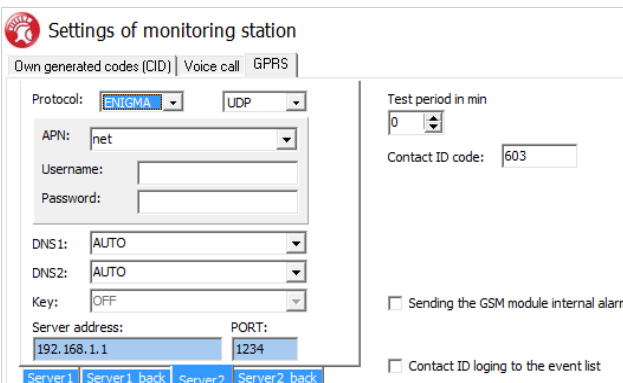

### GPRS settings

On this page the carrying protocol can be set for data transmission. We suggest TCP usage only in justified situations, the UDP communication facilitates much quicker communication.

- In the latter case no need for user and password input.
- Compatible communication protocols are ENIGMA and SIA IP.
- At server address IP address and Domain name (this needs DNS server configuration) is also accepted.

- Backup servers can also be used to ensure communication.
- Frequency of the test message can be set. A special Contact ID code can also be assigned to it.
- At GPRS client code module uses the client code saved on the Voice call tab when forwards via GPRS/IP.
- Own tokens can be set (inputs, power supply monitor, tampering, life signs). Codes associated to this can be set on the Remote Surveillance tab.
- Logging Contact ID sent codes are saved in the module event log.

**Other settings options**

Other module settings can be found on this tab. For better accessibility we have organized these parameters along several categories: general voice call and SMS.

**On General tab you will find the followings:**

- **Extension card selection** (EXP Relay or EXP Alarm)
- **Arming with impulse**; by selecting this option an impulse sent to the input of EXP Alarm will cause arming/disarming.
- **Entry postponing** used with delayed input
- **Exit postponing** defines the time devoted to leave zones after arming
- Setting SMS message when alarm **comes in effect** (SMS command: 1234SMSTEXT16=sms text\*).
- **PC security code** modification (at empty field the code is not required)
- When in closed closure (using tamper microswitch) **module LEDs can be switched off**.
- **Saving output state** to inner memory, so at powering on output state will be set according to what was saved.
- **Activation with caller identification** can be set here if we want to arm/disarm the module with a call.
- **Input sensitivity** (in switched off state: 10 ms, low: 100 ms, normal: 400 ms, average: 1 sec, high: 5 sec)
- **Voice menu switch off** can be made here

**On Voice call tab you can find the followings:**

- Voice call parameters: setting **ringing and talking time** and number of **call attempts**. (SMS command: 1234RINGTIME=030 → ringing for 30 seconds)
- Selecting multiple call option every notified phone number has to acknowledge the call.

**On SMS tab you can find the followings:**



- **SMS forwarding** to one of the 8 telephone numbers. Warning! Never select the number of the module
- OAlso here you can set the **SMS programming security code**
- **Daily SMS limit:** it can be set how many SMSs can the module send a day. This limit can be removed by entering 255. **If you set limit to 0 the module will not send any SMS!**
- Number of **maximum SMS sending attempts** also can be set.
- **Forwarding SMS** arriving to the module to the phone number to be notified. (SMS order: 1234REDIR=1...8)
- **SMS header, which will appear at the beginning of messages.** Programming with Android based mobile phone

## Androread

### Connecting to the module

You can download the application in the Google Play for free without ads.



When you launch the application first you must pair the choose GSM module with the Androread. With the **Available Devices** button you can connect to the desired GSM module. In addition, the module connects automatically. Therefore, giving a pairing code is not necessary.

By tapping the **Paired Devices** button and choosing a device, a status line runs while the program reads out actual module settings and state.

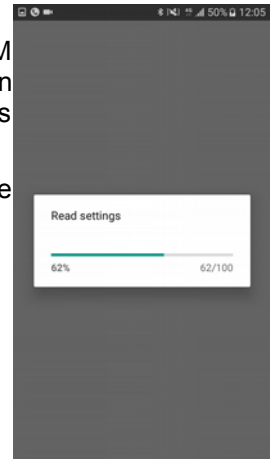

### The menu tree



• The settings can be achieved in the menu in two ways either sweeping among the screens, or by tapping the menu button in the lower-left side of the bottom.

With the menu button we can reach all of the settings promptly.

We have the possibility to configurate the main settings of the communicator includes notified phone numbers, output control, input settings etc. When we have modified the settings, we can send the settings to the module by tapping the icon at the bottom of the screen.

If you require help for the software, you can achieve the description of every screen by tapping the icon in the upper-right corner of the screen.

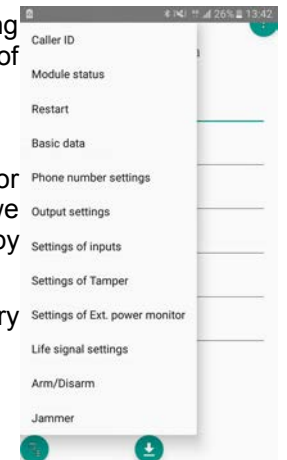

### Caller ID/Module status

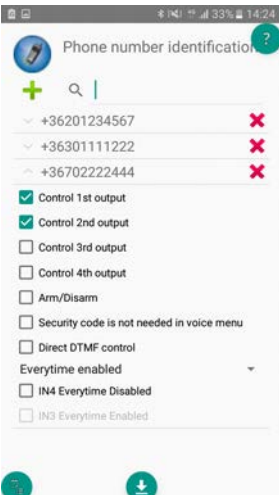

By choosing the „Caller ID” option, we can save phone numbers to the memory of the module. First the module reads out the phone numbers from the memory. Afterwards, we can give the numbers along with assigning the different functions like arming/disarming or controlling output 2. We can store up to 1000 phone numbers.

The software allows us to check the actual status of the module on the **Module status menu**. Here we can see the state of the inputs, outputs, tamper, power supply. Also, it indicates the state of the GSM signal strength and the actual state of the GSM network.



## Programming with SMS commands

Module can also be programmed by SMS commands. SMS starts always with the security code that can be modified whenever you want. Commands can be piled but the SMS length must be under 160 characters. The module (if it is possible) will send reply SMS after every message. You can switch this off with **NO SMS** command or with the **RECALL** command when the module makes a call to confirm the successful programming.

Command criteria:

- can not contain accented characters
- command characters are capitals
- commands have to be separated with space
- besides = you can also use #.
- messages have to start with security code that is followed by first command without space
- SMS text command has to end with # character

### Command List:

Description	SMS command		x value	value after = sign	Example
editing SMS security code	CODE			= new security code	<b>1234CODE=4321</b>
adjust clock	CLOCK			= yymmddhhmm yy: year, mm: month dd: day, hh: hour mm: minute	1234CLOCK=1401200922 Date will be: 2014.01.20 09:22
save telephone number for caller identification	ADD			= telephone number (with +36)	<b>1234ADD=+36305551234</b>
removing telephone number from caller number identification list	DEL			= telephone number (with +36)	<b>1234DEL=+36305551234</b>
saving/editing telephone number for notification	TEL	x	telephone ordinal number from 1 to 8	= telephone number (with +36)	<b>1234TEL1=+36305551234</b>
input setup	INPUT	x	input ordinal number	= tnnneeeeeee t:0 → switched off, 1→24 h normal, 2→ backup; 3→ normal alarm 4→ delayed alarm nn→ NO or NC eeeeee...: Other parameters: 1.e=1→ send SMS of status reversion 2.e=0→ compulsory 0 3.e=1→siren sound 4.e=1→voice message 5.e=1→remote surveillance 6.e=1→ no need to pickup when calling 7.e=1→DTMF confirmation (#) 8.e=0→ compulsory 0	<b>1234INPUT1=INC00100000</b> First input is: -24 h normal -Normal Close - not sending SMS when reverts back to initial state - plays siren sound when calling - no voice message - no remote surveillance notification - when calling must be picked up -no need for DTMF confirmation
Output setting	OUTCONF	x	output serial	= iiiirhnr iiii→if 00000 then it will be bistable, otherwise it is the duration of control in seconds r→ controlled when alarm h→controlled when call n→=1→ without caller identification	<b>1234OUTCONF=00003110</b> output is in 3 seconds monostable mode, it can be controlled by call and alarm and number identification is a must during a call
Life sign sending	LIFETEST			= cccsstttttt ccc→cycle time, how often to send message (ex.:030 days) ss→on the given day at what time (ex.: at 12 o'clock) ttttttt→ which telephone number to choose from the 8 ex.: 00100000→3 <sup>rd</sup> phone number, 01010000→2 <sup>nd</sup> and 4 <sup>th</sup> etc.)	<b>1234LIFETEST=0071100100100</b> -in 7 days -at 11 a.m. -sending to 3 <sup>rd</sup> and 6 <sup>th</sup> telephone number
Setting up notification sending	SEND	x	1:1 <sup>st</sup> input	= ssssssssvvvvvvvv	1234SEND2=0010000011110000

			2.: 2 <sup>nd</sup> input 3.: 3 <sup>rd</sup> input 4.: 4 <sup>th</sup> input 9.: tamper 10.: power source monitor 12.: life sign	sssssss→ selecting phone numbers for SMS notification (0 or 1) vvvvvvv→selecting phone numbers for call (0 or 1)	
	SMSTEXT	x	1.: 1 <sup>st</sup> input 2.: 2 <sup>nd</sup> input 3.: 3 <sup>rd</sup> input 4.: 4 <sup>th</sup> input 9.: tamper 10.: power source monitor 12.: life sign 16.: reverting text	= SMS text ending with *. Text must not contain accented character!	1234SMSTEXT1= alarm text*
Forwarding inbound SMSs	REDIR			= phone number serial from 1 to 8	1234REDIR=2
Setting ringing time	RINGTIME			= from 001 to 255 (in seconds)	1234RINGTIME=030 rings for 30 seconds
Requesting module status information	INFO			Command	1234INFO
no SMS after SMS programming	NOSMS			Command	1234command1 command 2 ... NO SMS
output control	OUT	x	output numbers	= ON→switch on OFF→switch off RUN→controlling according to settings sssss→ controls the output for a limited time (in seconds)	1234OUT1=ON Output 1 switches on 1234OUT2=OFF Output2 switches off 1234OUT3=RUN Controlling output 3 1234OUT4=00003 Output 3 switches on for 3 seconds
Restarting module	RESTART			Command	1234RESTART

**SMS command examples:**

1<sup>st</sup> message: input setup and selecting 3<sup>rd</sup> telephone number for notification. Sending SMS and voice message to the 3<sup>rd</sup> number.

**5384TEL3=+36201255335 CLOCK=1401200922 INPUT2=4NO00100000 SEND2=0010000000100000**

SMS text is the following:

**5348** → SMS security code, every new SMS can be started with this code (to change it use the CODE command. Default code: 1234)

**TEL3=**→changing 3<sup>rd</sup> telephone number for notification. Give the number in international format.

**CLOCK=** change the date to the following: 2014.01.20 09:22

**INPUT2=**→ setting 2<sup>nd</sup> input to the following: delayed normal open input that sends siren alarm when there is an event.

**SEND2=**→second input sends SMS and voice message to the 3<sup>rd</sup> telephone number

2<sup>nd</sup> message:

- to modify the SMS text of the second input
- output and life sign message setup and
- saving an output controlling number for controlling
- finally modify the SMS security code

**5384=SMSTEXT2=second input alarm" OUTCONF1=00003010 ADD=+36705553456**

**LIFETEST=007123000100000 CODE=2345**

**SMSTEXT2=**→modify SMS text of second input. No accented characters!

**OUTCONF1=**→ output setup: monostable for 3 seconds with caller identification

**ADD=**→Adding telephone number to caller identification

**LIFETEST=**→sending life sign weekly at 12:30 to the 3<sup>rd</sup> telephone number

## GSM gate control compact view

Similar to the entryphone compact view GSM gate control settings have their separate interface. The new interface contains every significant function for establishing a GSM based gate control system.

To activate the interface on the Connection window the Gate control compact view checkbox has to be marked

The new interface contains:

- output (gates) configuration: monostable (timed) or bistable (two stated) controlling
- controlling with caller identification, assigning phone numbers to gates and direct DTMF control
- SMS and PC security code
- firmware update
- switch off PIN code request of the SIM card
- event log, GSM signal strength and showing actual GSM module status
- wiring diagrams

For GSM gate control programming you have to complete only 4 (+1) steps:

### First step: set up the outputs.

- You can freely change the output settings
- Controlling can be monostable (one stated) or bistable (two stated)
- At monostable operation controlling time period can be even 65,000 seconds
- Controlling can be made with caller number identification or without identification from unlimited telephone numbers
- By using the Test button you can try the current settings. To use the 2nd, 3rd and 4th output an output expander (EXP Relay or EXP Relay3) is needed

### Second step: save the controlling phone numbers

- You can store up to 1,000 phone numbers in the module memory
- phone number must comply with the international format (+ followed by country code)
- By selecting the controlling phone number you can choose which output should be controlled with that number
- To control the module you just have to ring it. If you switch on direct DTMS control module will accept your call and you can control the outputs with the buttons of your cell phone

### Third step: mind the security of your device

- Change the SMS security code and (optionally) set your PC programming code. Default SMS security code is 1234.

### Fourth step (optional): other settings

- By clicking the Other settings button you can set GSM module related notification possibilities
- notification of power failure and its restoration can be sent
- you can set life sign sending so the device will send SMS of its seamless operation
- messages arriving to the device can be even forwarded to your phone

The final 5th step is to send settings to the GSM device



## MEGFELELŐSÉGI NYILATKOZAT

Mi:

A Tellsystems Communication Kft.(2040 Budaörs, Károly Király út 90)

(gyártó vagy felelős képviselőjének neve, címe)

felelőségünk tudatában kinyilvánítjuk, hogy a(z)

### **ProCon GSM és EasyCon GSM GSM átjelző SimCom GSM modullal**

(termék megnevezése, kereskedelmi név, típus- vagy modellszám, szériaszám)

berendezés teljesíti az 1999/5/EC irányelvben meghatározott alapvető követelményeket és más vonatkozó rendelkezéseket ill. megfelel a rádióberendezésekről és az elektronikus hírközlő végberendezésekről, valamint megfelelőségük kölcsönös elismeréséről szóló 5/2004. (IV.13.) IHM rendeletnek és az elektronikus hírközlésről szóló 2003. évi C. törvény 80. §-ában szereplő alapvető követelményeknek, továbbá megfelel az alábbi szabványokban és/vagy normatív dokumentumokban foglalt követelményeknek:

**EN 301 511 v9.0.2 (03/2003)**

**EN 301 489-1 v.1.8.1 (04/2008)**

**EN 301 489-7 v.1.3.1 (11/2005)**

**EN 60950-1:2006+A11:2009**

(szabvány megnevezése, dokumentum megnevezése és kiadásának ideje)

Az együttműködő bejelentett tanúsító szervezet(ek):

*MATRIX Vizsgáló, Ellenőrző és Tanúsító Kft.*; azonosító szám: 1413  
(tanúsító szervezet(ek) neve, EU azonosító száma)

A berendezés műszaki konstrukciós dokumentációja a

**Tellsystems Communication Kft.(2040 Budaörs, Károly Király út 90)**  
(elérhetőség megnevezése)

címen érhető el.

*Budaörs, 2011. május 27.*  
(hely és idő)



(képviselési joggal rendelkező személy aláírása, neve és beosztása)